

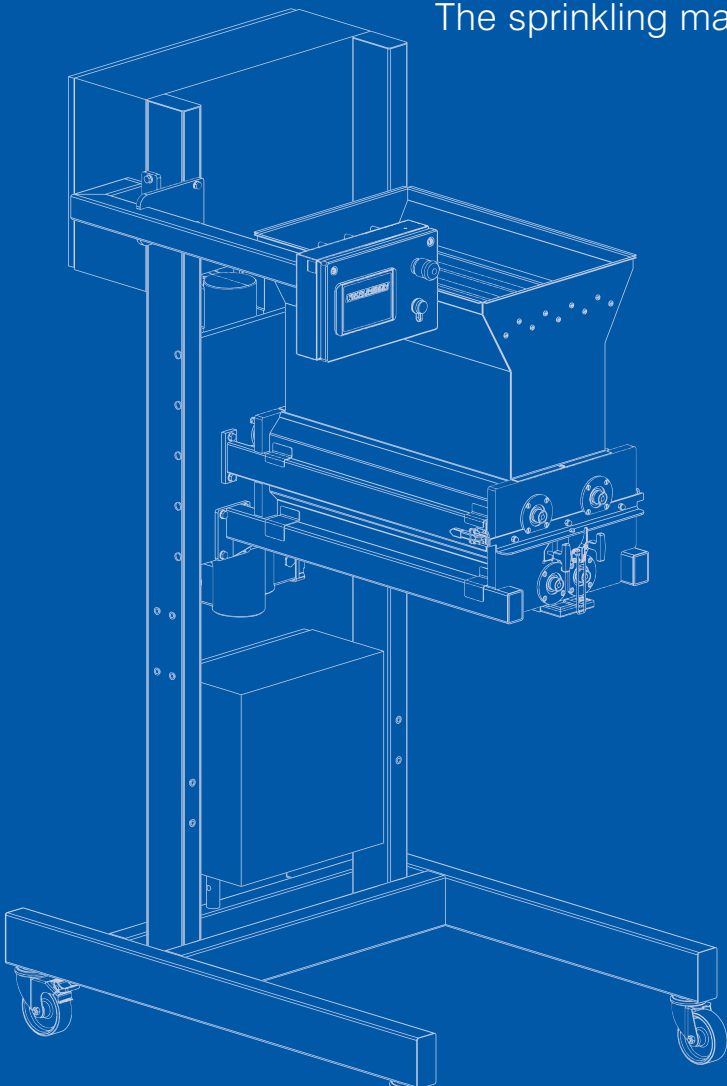

USS1-S2

SPRINKLING SYSTEM

The sprinkling machine for the application of sprinkle toppings



consistent

continuous

flexible

 made
in
Germany

 **KRUMBEIN**
food in process

For more
information:



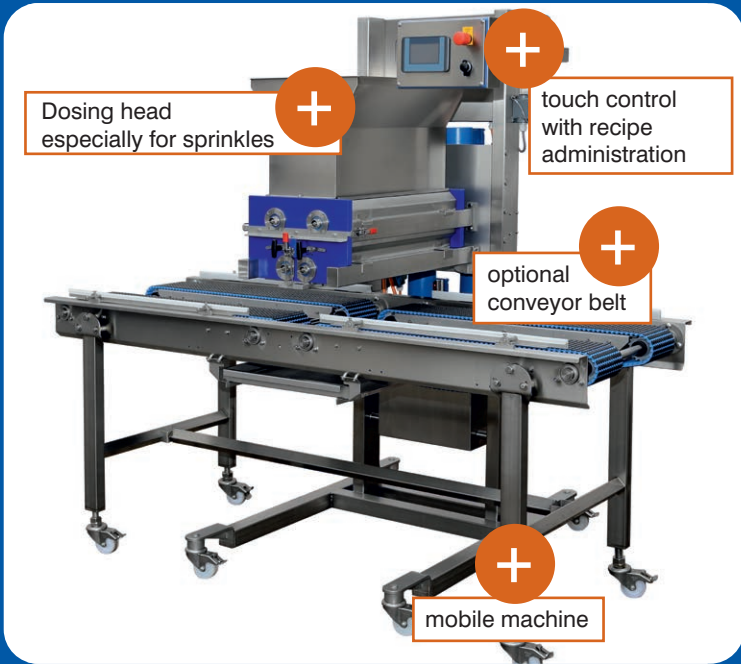

BENEFITS

- ✓ Available with or without conveyor belt
- ✓ Infinitely variable adjustment of the sprinkling intensity
- ✓ Possible use on top of external line without conveyor belt
- ✓ Consideration of the size and shape (extra fine or coarse) through the speed adjustment of each sprinkling roller
- ✓ Easy disassembly of important machine parts for an effective cleaning – without tools
- ✓ Rinsing in the dishwasher



MAIN FEATURES

- ▶ Easy to operate
- ▶ Sprinkling machine for the even distribution of sprinkle toppings
- ▶ Modular construction (C-Frame)
- ▶ Hygienic design
- ▶ Sprinkling pattern appears hand-crafted



AVAILABLE OPTIONS

- ▶ Conveyor belt for trays (grid belt) as well as for products (round belt) usable
- ▶ Machine without conveyor can be used on top of an external transport band
- ▶ Interlinking with other machines possible



PRODUCT GALLERY



KRUMBEIN rationell GmbH & Co. KG
Bäckerei- und Konditorei-Technik, Maschinenbau
An der Schaltstation 3b
99891 Bad Tabarz / Thüringen

Phone: +49 (0)36259 58015
E-Mail: info@krumbein-rationell.de
Web: www.krumbein-rationell.de

Distribution partners
in your region:

