

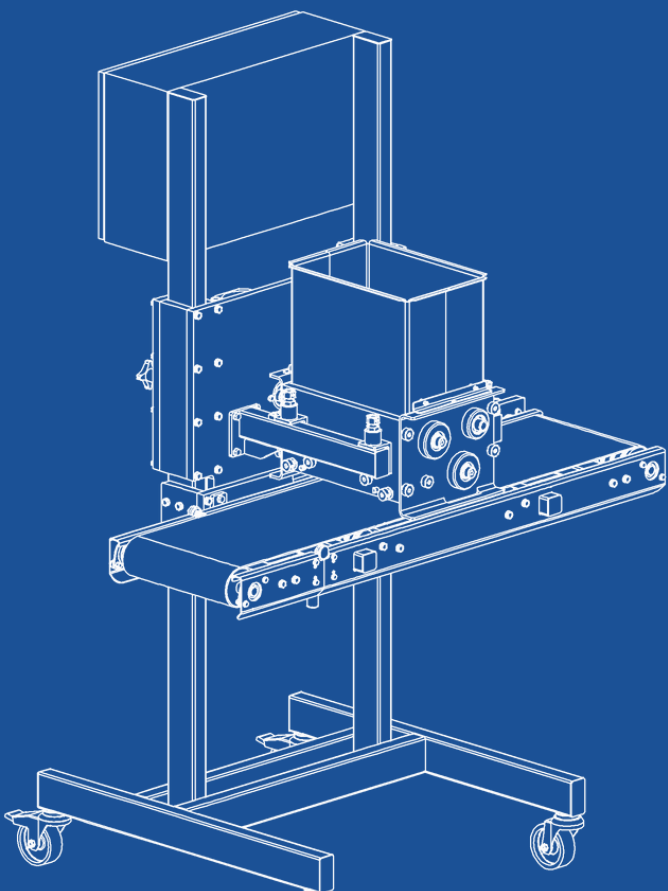

WBS 300 / 600

BUTTER SPREADING SYSTEM

Efficient solution for flat buttering



S
B
W

fast

flexible

efficient

 made
in
Germany

 **KRUMBEIN**
food in process



Continuous process



continuous adjustment of the application thickness



mobile machine



BENEFITS

- spreading system for the flat application of spreads on suitable products (mayonnaise, sandwich spread, whipped butter etc.)
- for sliced bread, sandwich spread, Finn bread, pita bread
- Infinitely variable regulation of the working speed
- adjustable application thickness
- high productivity
- max. product height 40 mm



KEY FEATURES

- buttering by contact spreading method
- ensures process-reliable work
- single-track, compact, mobile machine
- manual product feed or automatic transfer of a conveyor belt
- stepless regulation of the feed speed
- high safety standard
- very easy to dismantle for cleaning - no tools required
- hygiene design - for quick and effective cleaning
- machine parts easy to clean in dishwasher
- can be linked with the KRUMBEIN production line
- two working widths selectable: 300 and 600 mm



PRODUCT GALLERY



KRUMBEIN rationell GmbH & Co. KG
Bakery- and confectionary machines
Mechanical engineering
An der Schaltstation 3b
99891 Bad Tabarz / Thüringen

Phone: +49 (0)36259 58015
E-mail: info@krumbein-rationell.de
Homepage: www.krumbein-rationell.de

sales partner
for your region:

